



CORDIS SERIES Custom Calibrated Pressure Sensors

Operating Instructions



Known for reliability, innovation and focus on miniature pneumatics, Clippard has now expanded the Cordis family with a new transducer line. These piezoresistive silicone pressure sensors can either be used as feedback for the CPC Pressure Controller or as a standalone transducer. Current optional outputs are 0 to 5 VDC, 0 to 10 VDC and 0.5 to 4.5 VDC. These transducers are conditioned, temperature-compensated and offer a customized calibration specific to the application requirements. This allows for a full-scale accuracy of 0.25% over the calibrated range.

Multiple mounting options allow the user to place the sensor downstream or in a remote location from the pressure controller. This creates a quicker response and helps avoid any lag in the system.

The manifold mount lends itself well to analytical value-added assemblies. All wetted materials are Oxygen compatible and manifold mounting eliminates any possible contamination during assembly.

Content

2 Technical Data

2-3 Operational Description

3 Mounting

4 Calibration

5 Electrical Connection

5 Ordering Information

6 Contact Information

6 Limited Warranty

6 Other Useful Material Links

clippard.com/link/sensors

Technical Data

Table:1

ELECTRICAL	
Voltage	15 to 24 VDC
Current Draw	< 250 mA max.
Signal Output	0 to 5 VDC, 0 to 10 VDC or 0.5 to 4.5 VDC Analog

PERFORMANCE	
Calibrated Range	Vac to 150 psig/Customer Supplied Value
Accuracy	± 0.25% of full scale
Linearity	± 0.25% BFSL
Response Time	< 5 ms

OPERATING CONDITIONS	
Operating Temperature	32 to 158°F (0 to 70°C)
Medium	Clean, dry, non-corrosive gases
Mounting Attitude	Any

WETTED MATERIALS	
Elastomers	FKM
Manifold/Housing	Anodized Aluminum/IP65 Rated
Fitting	ENP Brass
Pressure Sensor	High temperature polyamide, alumina ceramic, silicone epoxy, glass
IP65 Housing	Polycarbonate

MORE DETAILS	
Website	clippard.com/link/cordis

Operational Description

The Cordis CPS Pressure Sensors are piezoresistive silicone pressure sensors that can either be used as the feedback signal to the CPC Pressure Controller or as a stand-alone pressure transducer. Current standard signal outputs are 0 to 5 VDC, 0 to 10 VDC and 0.5 to 4.5 VDC. These pressure transducers are conditioned, temperature compensated and offer a customized calibration specific to your application requirements. This allows for a full-scale accuracy of ±0.25% over the customized calibrated range.

Multiple mounting options allow the user to place the sensor downstream or in a remote location from the Cordis pressure controller. This helps eliminate mechanical hysteresis from pilot regulators or provides feedback from critical application points.

The Manifold Mount version lends itself to analytical value-added assemblies which reduces the possibility of creating contamination due to threaded ports.

When the CPS Sensor is used as the feedback to the Cordis CPC Pressure Controller (Z Option/Type), the internal pressure transducer is removed from the CPC unit making the CPC Sensor (Z Option) the primary feedback signal.

Z Option is typically utilized when piloting a mechanical volume booster which increases the downstream volume flow for fill and bleed circuits. Due to the mechanical hysteresis found within the various types of pilot volume boosters, an external sensor is used to help reduce this hysteresis and provide greater accuracy. For example, the CPS Sensor would be placed in the output gauge port of the pilot booster. With the CPS Sensor connected back to the CPC Pressure Controller, now the mechanical error can be seen and eliminated simply by the comparative circuit. Additional applications for the Z Option would be to have the CPC Sensor mounted closer to a critical measurement/control area.

When using the Cordis Z Option,, at no time can the external sensor be isolated from the CPC Control unit while under command. Isolation of the feedback signal will cause the comparative circuit to decrease or increase output pressure, depending on the difference on the difference, in an attempt to balance Command and Feedback signals.

Mounting

The Cordis CPS Series pressure transducers can be mounted in any orientation without negatively affecting process signal/control. There are four standard mounting connections available.

CPS-F Male 1/8" NPT **CPS-I** 7/16-20 UNF **CPS-M** Manifold **CPS-R** 1/8-28 BSPT

Thread Mount

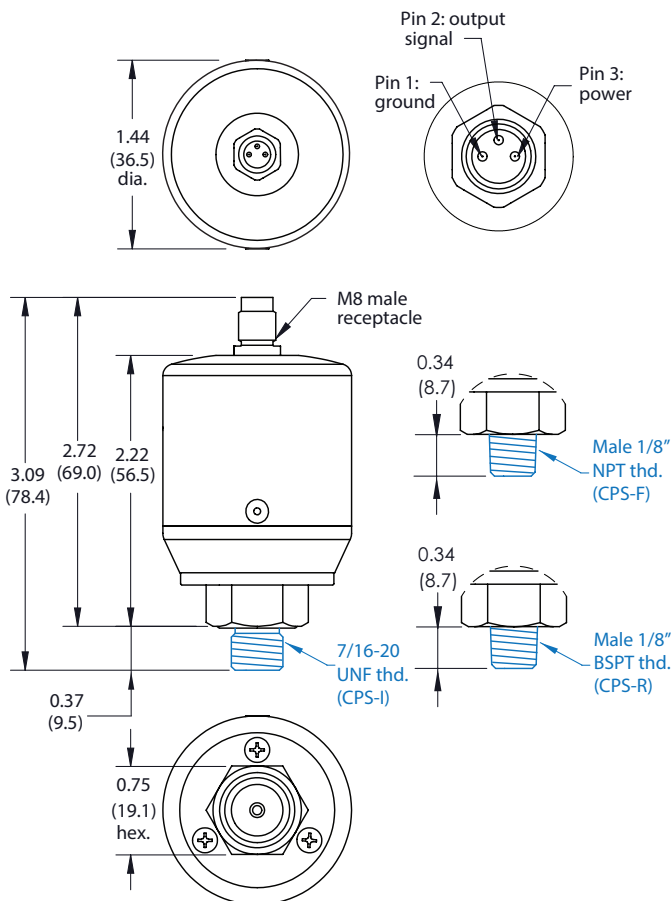

Manifold Mount

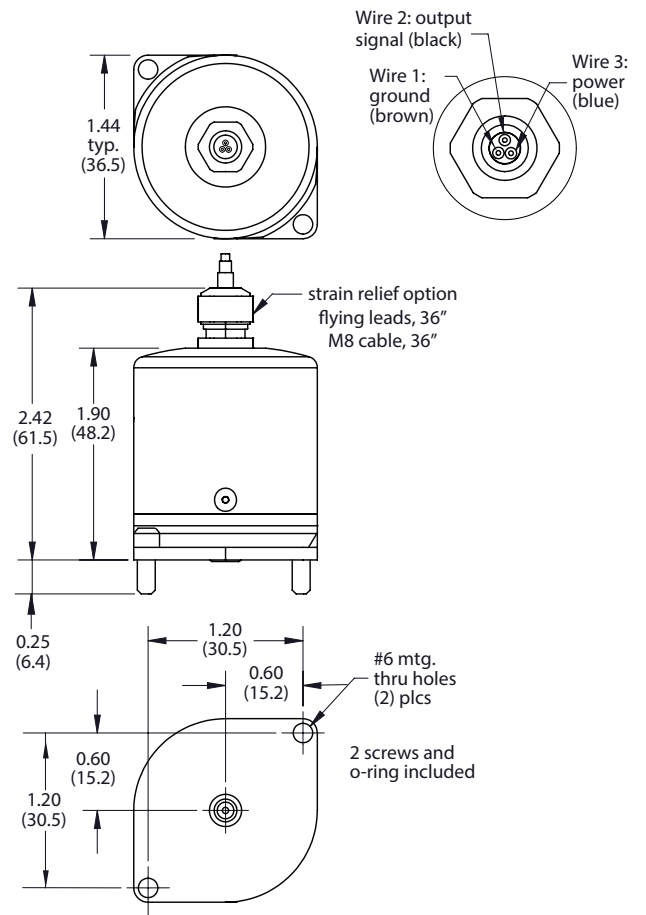

Calibration

The calibration of the Cordis CPS series pressure transducers is done at the time of manufacture to NIST traceable standards. Below are the available sensor ranges available along with the maximum allowed inlet/supply pressures.

Table:2

SENSOR RANGE	MAX. INLET/SUPPLY PRESSURE
0 to 1 psig	10 psig
0 to 5 psig	30 psig
0 to 15 psig	30 psig
0 to 30 psig	60 psig
0 to 60 psig	100 psig
0 to 100 psig	115 psig
0 to 150 psig	165 psig
0 to 15 psia	10 psig
0 to 30 psia	45 psig
0 to 100 psia	165 psig
-5 to +5 psid	25 psig
-15 to +15 psid	45 psig
0 to 10" H2O	5 psig
-10" to +10" H2O	6 psig
0 to 4" H2O	4 psig
-1 to +1 psid	8 psig

Table:3

CALIBRATED RANGE	MAX. INLET/SUPPLY PRESSURE
0 to 0,1 bar	0,70 bar
0 to 0,5 bar	2 bar
0 to 1 bar	2 bar
0 to 2 bar	4 bar
0 to 4 bar	7 bar
0 to 7 bar	8 bar
0 to 10 bar	11 bar

Downstream Sensor Ordering Guide

			-		-									
						Custom Calibrated Range								
Port Size			Signal Output		Standard Calibrated Range		Unit of Measure		± Pressure					
CPS-F	Male 1/8" NPT		E	0 to 10 VDC	-A	0 to 1 psig	-L	0 to 4 bar	-A	psig	P	Positive	P	Positive
CPS-I	7/16-20 UNF		F	0 to 5 VDC	-B	0 to 5 psig	-M	0 to 7 bar	-B	bar	V	Vacuum	V	Vacuum
CPS-M	Manifold		G	0.5 to 4.5 VDC	-C	0 to 15 psig	-N	0 to 10 bar	-C	psia	Offset - Low		Calibrated High	
CPS-R	1/8-28 BSPT				-D	0 to 30 psig	-O	0 to 15 psia	-D	mBar	0.00	Low End	0.00	High End
					-E	0 to 60 psig	-P	0 to 30 psia	-E	inHg	(manual entry)		(manual entry)	
Electrical Connection					-F	0 to 100 psig	-Q	0 to 100 psia	-F	mmHg				
A	Flying Leads, 36"				-G	0 to 150 psig	-R	-5 to +5 psid	-G	Torr				
B	M8 Cable, 36" *				-H	0 to 0,1 bar	-S	-15 to +15 psid	-H	H2O				
C	M8 Male 3-Pin Connector				-I	0 to 0,5 bar	-T	0 to 10" H2O	-I	kPA				
					-J	0 to 1 bar	-U	-10" to +10" H2O						
					-K	0 to 2 bar	-V	0 to 4" H2O						

* For use when connected to a Clippard CPC Cordis Pressure Controller only (-Z option)

Accessory Cable

CPSH-C1 Mating Cable, 36"
(for use with "C" Electrical Connection)





7390 Colerain Avenue
Cincinnati, OH 45239

1-513-521-4261
1-877-245-6247

Cordis, of the heart

Other Useful Materials

Cordis Proportional Pressure Controllers

Digital vs. Analog Control White Paper

Pressure vs. Flow Control White Paper

Resolution in Proportional Control White Paper

View Frequently Asked Questions

View Web Site

Limited Warranty

All information contained in this publication is for reference only. Proper design engineering procedures should be used to assure any compliances. Clippard Instrument Laboratory, Inc. reserves the right to make changes without notice and does not warrant or guarantee the information contained herein.

Clippard Instrument Laboratory, Inc. (Seller) warrants its products to be free from defects in material and workmanship for a period of one (1) year from the date of sale. Seller's liability shall be limited at seller's option to repair, replace or refund purchase price of product found by seller's examination to be defective. All claims under this warranty must be made in writing to seller's factory sales department giving full details, prior to return of product, postpaid, to factory. Seller shall not be responsible for product failure due to normal wear, accident, buyer's misapplication, abuse, neglect or alteration of product. Seller will not be responsible for any consequential damages. Clippard makes no other warranty of any kind, expressed or implied. Circuits shown in this catalog are for instructional purposes only. All circuits used on equipment and machinery should be thoroughly tested by qualified personnel under actual working conditions to determine their suitability for buyer's intended use. All technical data and operations are average values based on standard production models. Some deviations can be expected and considerations should be given during initial design stages. All operating characteristics are based on new equipment, under normal conditions of use and environments and oil free air supply. Dimensions stated may be nominal and are subject to change without notice. Contact Clippard for specific dimensional tolerances when dimensions are critical.

Proudly made in the USA.

6 - CORDIS | 877-245-6247 | clippard.com | tech@clippard.com

CLIPPARD INSTRUMENT LABORATORY, INC. • ISO 9001 • INS-9.22 • V1